

# SCOTSMAN

MODULAR ICE STORAGE BINS

## BH550

### VOLUME STORAGE – AMPLE ICE RESERVE

- Holds up to 410 lbs. per ARI standard 820-95.
- Large–easy access door.
- Ideal storage companion for the Scotsman 30” cubers and many other Scotsman nugget and flake ice machines.

### QUALITY CONSTRUCTION

- NSF Approved construction.
- Attractive stainless steel finish.
- Polyethylene bin interior.

### WARRANTY PROTECTION *See Dealer for complete warranty details.*

- 3 years parts and labor on all components.



Bin includes 6” black enamel legs w/ adjustable leveling.

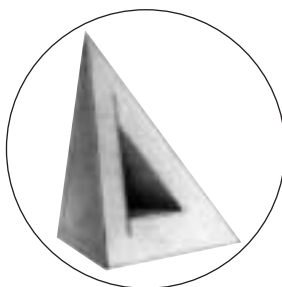

### FULLY INSULATED CABINET

Foam insulation is forced between the wall and liner under heat and pressure to form a perfect wall to wall bond thus preserving ice supply for long periods.



Scotsman is proud to announce that we are ISO-9001:2000 Certified



# Bin Specifications

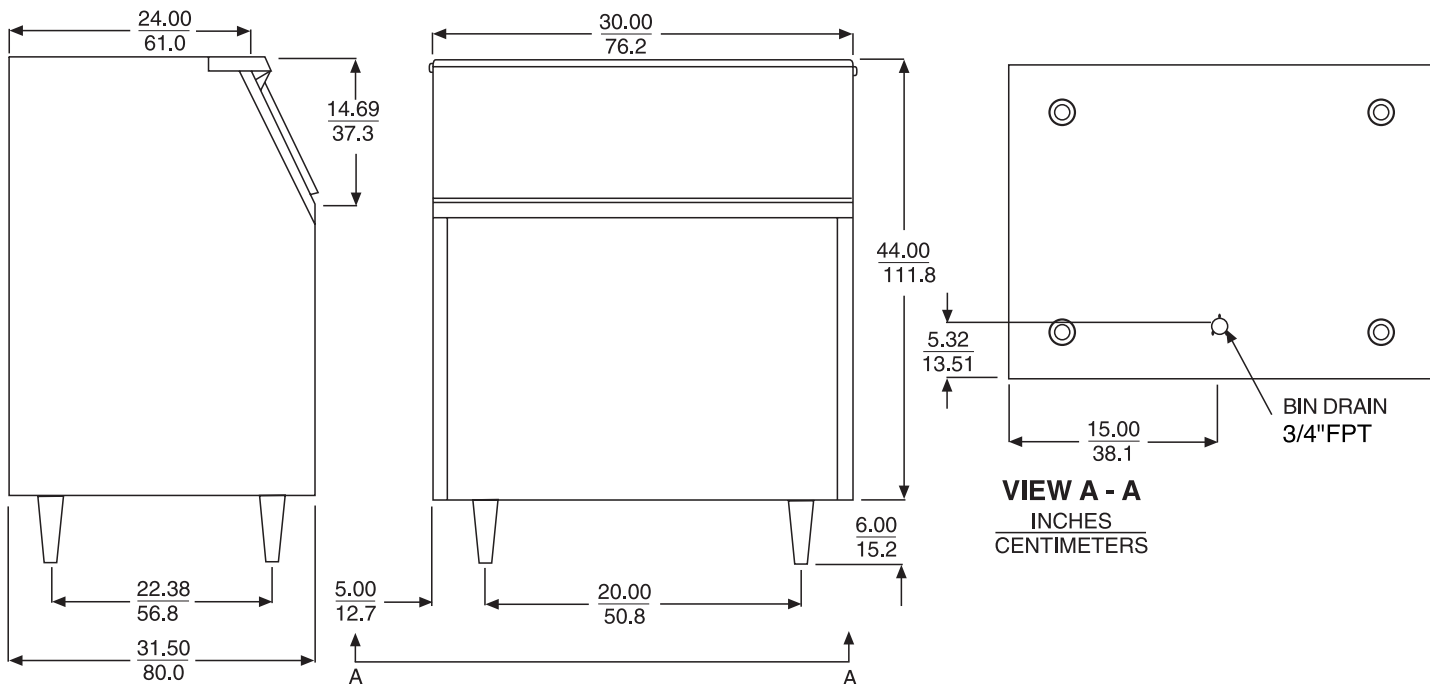

NOTE: Allow 6" minimum space at back for ice machine ventilation and utility connections.

SCOTSMAN MODULAR BIN					
					Certified & rated in accordance with ARI standard 820-95
Model Number	Dimensions W"xD"xH"	ARI Bin Capacity lbs./kg.	Application Capacity lbs./kg.	Finish*	Ship Weight lbs./kg.
BH550-C	30 x 31.5 x 44	410/186	520/236	SS	140/64

\*(SS) Stainless steel cabinet with a stainless steel liner.

NOTE: Add 6" height for legs.

ARI storage capacity for bins is based on 80% of total volume in cubic feet x 30 lb./ft.<sup>3</sup> average density of ice.

Application capacity for bins is based on 90% of total volume in cubic feet x 34 lb./ft.<sup>3</sup> average density of ice.

Scotsman's ice machines and bins are not designed for outdoor installations. Scotsman remote condensers are designed for outdoor installations.

Machine requires voltage indicated on rating name plate. Failures caused by improper voltage are not considered factory defects. Extended periods of operation at temperatures exceeding limitations constitutes misuse under the terms of Scotsman Manufacturer's Limited Warranty, resulting in a loss of warranty coverage. Specifications and design are subject to change without notice.

Consult Your Local SCOTSMAN Representative At:

## ACCESSORIES

Model Number	Description	Application	Ship. Wt. lb./kg.
KBT20A	Bin Top	Use with MFE400, NME654, NME954, FME804, FME1204.	25/11
KBT14A	Bin Top	Use with NME654, NME954, FME804, FME1204.	8/4
KLP4	Heavy-duty leg kit	6" aluminum legs & bracket. Must be used when machines are stacked.	25/11
KLP7	Flanged-feet leg kit	6" black enamel legs with flanged feet.	5/2
KBC1	Caster kit	Raises bin 47/16". Not to be used when machines are stacked.	8/4
KBC8	Caster kit	Raises bin 9.3/4". Not to be used when machines are stacked.	25/11
KHOLDER	Ice scoop holder	Fits all modular ice storage bins.	2/1

**YOU'LL VALUE THE DIFFERENCE™**

775 Corporate Woods Parkway • Vernon Hills, IL 60061 • 1-800-SCOTSMAN • Fax: (847) 913-9844  
Visit our website at: [www.scotsman-ice.com](http://www.scotsman-ice.com) • E-mail: [customer.service@scotsman-ice.com](mailto:customer.service@scotsman-ice.com)